



Manual Measuring Stage MTM 300 × 300 MR with Integrated Measuring System

Specifications

Measuring range	300 × 300 mm (12" × 12")
Accuracy	±5 µm
Resolution	0.05 µm (smallest step size)
Drive	coaxial drive / rack – pinion with patented coarse adjustment
Material	aluminium
Surface	anodic coating, black lacquered
Load capacity	5.0 kg
Weight	18.6 kg

Order Information

Order No.: 00-31-012-0000

Product Features

- ▶ with integrated measuring system
- ▶ equipped with patented coarse adjustment
- ▶ for reflected light applications

Accessories

Digital readout unit PROFILER SCD
 (included in delivery)

Order No.: 00-76-900-4830

Dimensions

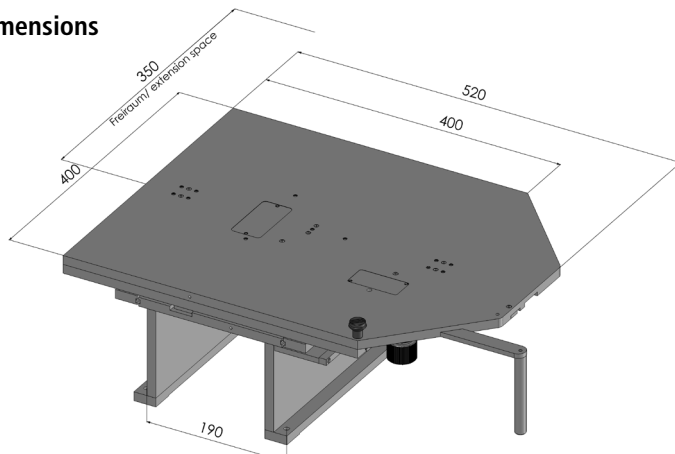

For more accessories for microscopy
 please visit: www.marzhauser.com